

Model-Based Engineering of a Process Wash Plant using SysML: Case study of beneficiation processes in a phosphate industry

Mariem Ait Bakader

Applied Organic Chemistry Laboratory
Faculty of Sciences and Technics,
Sidi Mohamed Ben Abdellah University, FES
FES, MOROCCO
Complex Systems Engineering Laboratory
Mohammed VI Polytechnic University, BENGUERIR
BENGUERIR, MOROCCO, mariem.aitbakader@usmba.ac.ma,
mariem.aitbakader@um6p.ma

Laurent Deshayes

Complex Systems Engineering
Mohammed VI Polytechnic University, BENGUERIR
BENGUERIR, MOROCCO
Laurent.DESHAYES@um6p.ma

Mohammed El Asri

Applied Organic Chemistry Laboratory
Faculty of Sciences and Technics,
Sidi Mohamed Ben Abdellah University, FES, MOROCCO
FES, MOROCCO
mohammedelasri@yahoo.fr

Abstract

The fourth industrial revolution is being fostered in many countries to make more efficient and flexible plants. Industry 4.0 target is to get a more competitive industry. Under this framework, improvement of mineral processing requires knowledge of previous methods and current technology in order to develop new techniques and approaches. As phosphate deposition decreases, the need for new recovery methods keeps growing. From this perspective, the need for control and optimization of existing processes becomes a necessity. It also includes the development of equipment with more advanced digitized components. The objective of our work is to develop a model of a process plant using SysML. In this paper, we adopted a system engineering-based approach, which consists on modeling and formalizing knowledge collected in the field. A well understanding of phosphate value chain allows both driving and optimizing current processes. In addition, we used this approach to model information flows in which we integrated a specific equipment in the overall process. This model will follow a systems engineering approach. In this paper we present the development of the SysML model of a process plant (Wash plant of phosphate). The model includes the requirements as well as the structure, behaviour and activity diagrams. A specific type of mining processes were studied with aim of giving feedback on the implementation of system modeling for mineral processing.

Keywords: Phosphate Beneficiation, Mineral Processing, Model Based Engineering, Control, SysML, Optimization.

1. Introduction

Today we are in what is called the fourth industrial revolution (called Industry 4.0 or Connected Enterprise or Industrial Internet depending on the country or consortium) Kagermann and Wahlster (2013); vans and Anninziata (2012). This revolution is being integrated in many industries, such as mining companies that want to enhance their productivity by the digital transformation. Therefore, they require new strategic models for making their processes smarter, including full integration from sensors to planning. Industrial Internet tackles the challenges of the industry: increased functionality in products, more connectivity, high interdisciplinarity, more product/process complexity, very software intensive, digitalization, needs of simulation and visualization, comply with more demanding regulations, etc.

To achieve the new requirements traceability throughout the entire system lifecycle is needed, traceability from the initial requirements to the final physical product, Eigner et al. (2014); Stark (2011). The concept of Model Based Systems Engineering, Paredis (2012), provides methods to guide the cross-disciplinary, virtual product development process and to achieve the required traceability.

The concept of Model Based Systems Engineering, Paredis (2012), provides methods to guide the cross-disciplinary, virtual product development process and to achieve the required traceability. Model Based Systems Engineering (MBSE) is a multi-disciplinary engineering paradigm propagating the use of models instead of documents to support analysis, specification, design and verification of the system being developed, Gilz (2014). Using models instead of documents, a new discipline-neutral view of the system specification is created. The resulting system model helps to well understand and to overview the complexity of the developed system. System models are created by application of the Systems Modelling Language (SysML). The Systems Modeling Language (SysML), Friedenthal et al. (2014), is a general-purpose graphical modeling language for specifying, analyzing, designing, and verifying complex systems that may include hardware, software, information, personnel, procedures, and facilities. In particular, the language provides graphical representations with a semantic foundation for modeling system requirements, behavior, structure, and parametrics, which is used to integrate with other engineering analysis models.

The objective of our work is to develop a model of a process plant of phosphate using SysML.

This model will follow a systems engineering approach, starting from the requirements.

In this paper we present the development of the SysML model of a process plant of phosphate (the beneficiation activity of phosphate). The model includes the requirements as well as the structure, behaviour and activity diagrams. In this work a model transformation from SysML to a process simulation language (in this case Excel) is presented. This allows for the analysis and the control of the process in the design and development phases. The results of the simulation will be fed back to the SysML model for further use.

2. Wash Plant Description

Phosphate ore is a nonrenewable resource, but it is essential for agriculture, as a raw material for fertilizers. Phosphates cannot be really substituted and recycled. Feeding the ever-growing world's population is becoming a challenge and phosphate needs are always bigger (Sis and Chander, 2003).

Siliceous phosphate ores are generally beneficiated by a two-stage flotation technique using amine and fatty acids for silica based gangue and phosphates respectively. The beneficiation of phosphate ores containing carbonaceous gangue is complicated because of the similarities in the chemical behavior of the minerals present (Somasundaran 1975)

Preparation of phosphate starts with the activity of mining, usually by using draglines, the ore is then made into a slurry, and transported to wash plant by pipelines. There are different equipment for washing; trommels, log washers, and sandwich screens (Lawver et al. 1978)

The mission of the wash plant is to wet enrich phosphate from the extraction site. Enrichment consists in ridding the ore of its poorest particle size fractions, namely grains larger than 3150/2500 μm and smaller than 40 μm . This enrichment is made using specific treatments to raise its BPL (Bone Phosphate of Lime) content and prepare it for chemical treatment. Figure 1 shows the simplified flowsheet of the process of phosphate wash plant. The wash plant has three main sections:

- A section of phosphates washing, which consists of a scrubbing, screening and physical classification of the product (according to the size of the cuts);
- A flotation section for enriching of poor slices;
- A sterile sludge storage and water recovery section.

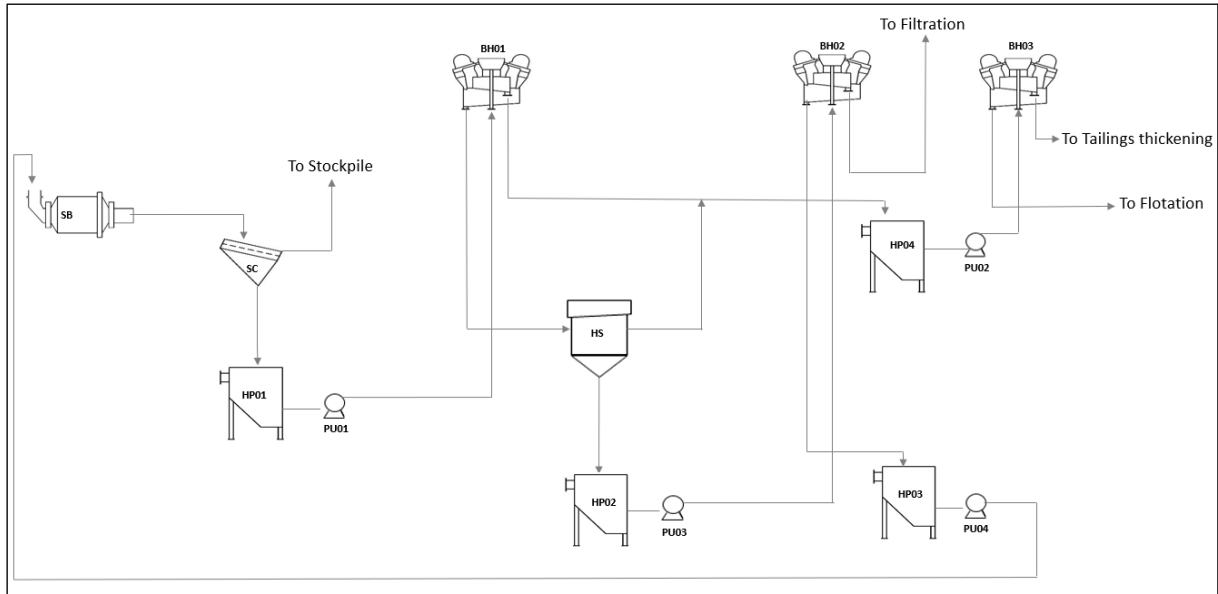

Figure 1: Simple Flowsheet of Phosphate Wash plant

3. SysML Model of the wash plant

We have followed the simplified MBSE method proposed by Friedenthal et al. (2014), to develop the model of the wash plant, which can be applied systematically if we follow a traditional functional analysis method. This method allows to specify the structure and functions of the plant and analyze its performance. SysML provides modelling diagrams and elements to capture the three.

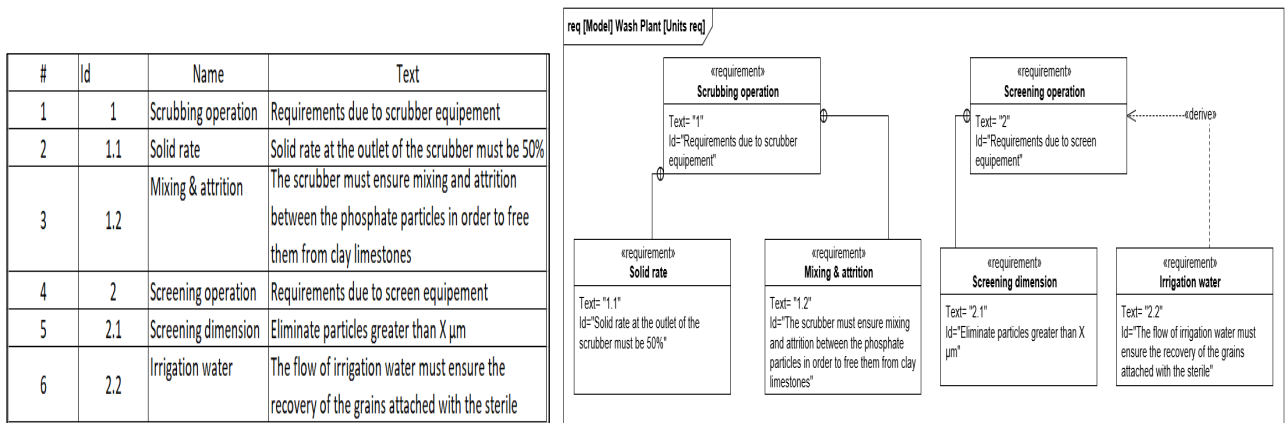

Figure 2: Different diagrams allow to capture the requirements of the Wash Plant in SysML

Wash Plant Requirements:

Foremost the plant requirement were established to capture the mission of the plant. Requirements are commonly used to formalize system prerequisites, resulting in features or conditions that should be satisfied by the System, depending on any priorities associated with the requirements. Requirements engineering is an essential part of systems engineering. Indeed, understanding the need facilitates designing the solution. Every requirement should be S.M.A.R. T: Specific, Measurable, Achievable, Relevant and Traceable (White book). One of the main advantages of SysML is that it allows to model the requirements of the system and derive from them the design, maintaining traceability. Different representations are possible: tabular, diagram, matrixes, to convey their organization, as shown in Figure 2.

Behaviour Modeling of the Wash Plant:

The refinement of the requirements results in the definition of the plant behaviour. Elaborating the overall behavior is the first step, it is refined in parallel to the design of the wash plant structure, where functions in the behaviour are allocated. Figure 3 indicates the fundamental functions that occur in the wash plant as SysML activities.

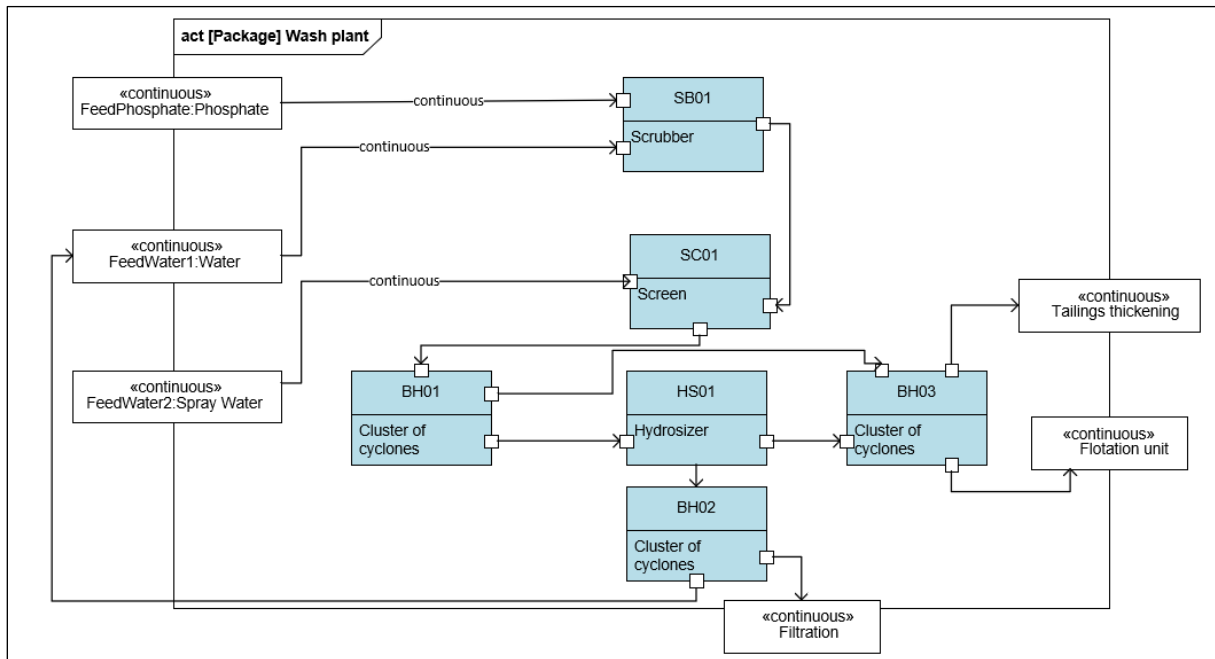

Figure 3: Overall activity diagram of the wash Plant

Structure Modeling of the Wash Plant:

The wash plant is modelled as an overarching block that contains blocks. In SysML structure is modeled with blocks as main elements. we discuss the system implementation. We adopt a decomposition approach of the system into subsystems to model its configuration. In this decomposition, we must begin by defining the system on which we will work. Then we must go into the granularity of the process.

4. SysML Model for Excel simulation

Excel simulation models allow the unification of the information in a single model, it allows the analysis of properties and performance through simulation. In this simulation, the integration of advantages of MBSE allows a well understanding of the wash plant, this would optimize the engineering processes and the collaboration between the different engineering departments in the process.

The preparation of the Excel material balance was made from the particle size distribution obtained at the laboratory scale. The results found make it possible to calculate the mass flow rate of solid (ton/h), the water flow (m³/h), the solid rate (%), the density (ton/m³) and the volume flow rate of the pulp (m³ / h) at the output of each equipment. (Figure 4)

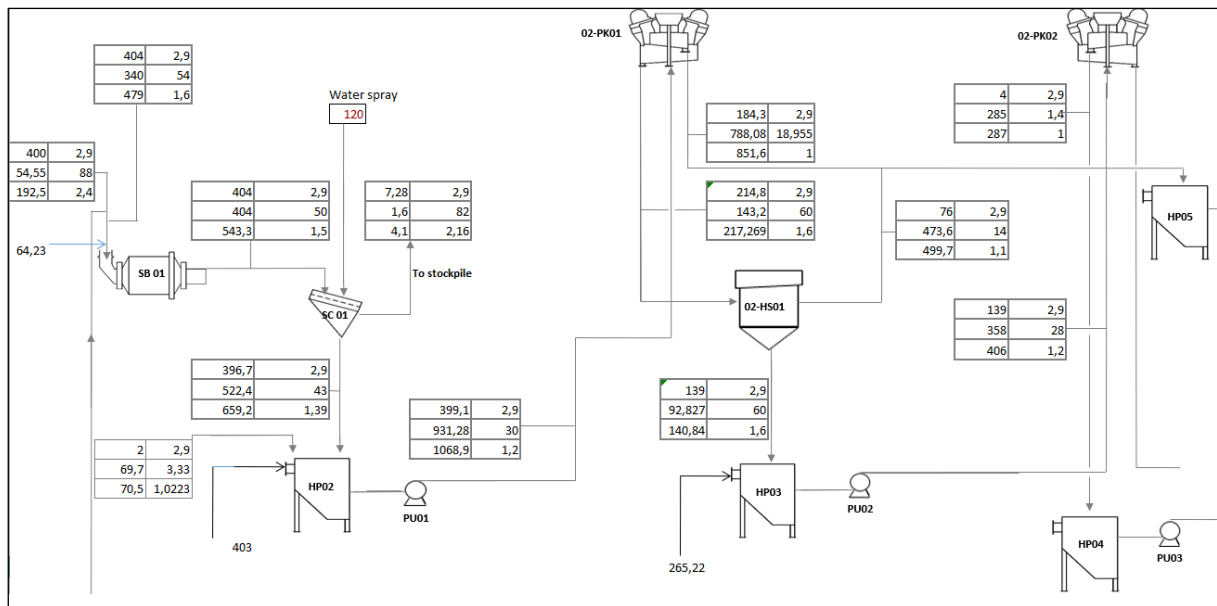

Figure 4: Generation of an Excel simulation based on material balance

5. Conclusions

Model-Based Engineering is necessary for the engineering of the industry 4.0 systems. In this paper we have developed a SysML model of a process Wash Plant of phosphates. This model can be used for the design of the plant and for all the engineering activities through the plant life cycle. Our adopted approach summarizes various modeling tools working with a well-known industrial partner in Phosphate valorization. Using these approaches, we will guarantee efficient beneficiation processes by optimizing their operating parameters. Simulation through Excel allows the analysis of properties and performance of each equipment.

In future works, we will investigate the possibility to generate Excel simulation from any SysML model by defining a map from SysML to Excel elements.

References

- Eigner, M., Dickopf, T., Apostolov, H., Schaefer, P., Faißt, K.-G., Keßler, A., 2014. System lifecycle management: Initial approach for a sustainable product development process based on methods of model based systems engineering. In: Product Lifecycle Management for a Global Market. Springer, pp. 287–300.
- Evans, P. C., Anninziata, M., 2012. Industrial internet: Pushing the boundaries of minds and machines. Tech. rep., General Electric.
- Friedenthal, S., Moore, A., Steiner, R., 2014. A Practical Guide to SysML, 3rd Edition. Morgan Kaufmann.
- Gilz, T., 2014. Plm-integrated interdisciplinary system models in the conceptual design phase based on model-based systems engineering. Ph.D. thesis, Techn. Univ.
- Gilz, T., 2014. Plm-integrated interdisciplinary system models in the conceptual design phase based on model-based systems engineering. Ph.D. thesis, Techn. Univ.

Kagermann, H., Wahlster, W., 2013. Recommendations for implementing the strategic initiative INDUSTRIE 4.0, Final report. Tech. rep., Industrie 4.0 Working Group.

Lawver .J.E, McClintock.W.O, and Snow.R.E, 1978.Beneficiation of phosphate rock a state of the art review, Minerals Science and Engineering, Vol. 10, No. 4, pp. 278–294.

Sis.H, Chander.S, 2003. Reagents used in the flotation of phosphate ores: a critical review, Minerals Engineering, 16, pp. 577-585.

Stark, J., 2011. Product lifecycle management. 21st Century Paradigm for Product Realisation. Springer.

Somasundaran.P, 1975.On the problem of separation of calcite from calcareous apatite. In: 11th Int. Miner. Process. Congress, Cagliari. Vol. 2, pp. 155-156.

White book, Requirements engineering for an information system, Compliance Consulting, p .11.

Biographies

Mariem Ait Bakader Ph.D. student in Applied Chemistry laboratory at the Faculty of Science and Technology of FES in the University Sidi Mohammed ben abdellah, and Process Engineer graduated from National School of Applied Sciences KHOURIBGA. She is also a member of the laboratory research team: Complex Systems Engineering at Mohammed VI Polytechnic University. Her research fields are Process Optimization, Phosphate beneficiation, Complex System Engineering.

Laurent Deshayes is currently deputy director of the complex system engineering laboratory at the Mohammed VI Polytechnic University in Morocco. Mr. Deshayes holds an Engineering Degree in Industrial Systems from the National Engineering School of Tarbes, France and a PhD Degree in Mechanical Science from the National Institute of Applied Sciences in Lyon, France. He taught courses in industrial management, advanced automation, manufacturing execution systems. He is currently developing living labs and research platforms for mining and chemical processes in order to build strong Moroccan and African competencies in advanced engineering areas such as System Engineering, Advanced process control, real time scheduling, industrial digitization and Beneficiation processes.

Mohammed El Asri is currently a fulltime lecturer in Faculty of Sciences and Technology, Sidi Mohamed Ben Abdellah University. Also is head of Research Team: Macromolecular and Applied Chemistry. Mr. EL ASRI PhD in Materials Chemistry at Montpellier II University. He supervised several research projects and PhDs. He has taught courses in polymer and organic chemistry and Thermochemistry and kinetics. He has also taught optimization and control of industrial process by design of experiment. He coached several companies on control and optimization from projects by DOE. He is also an expert and trainer with a Saiss Opex consulting firm.